

An Atlas  
of Commoning

*Typologien der  
Gemeinschaft*

ConstructLab  
Modem Studio  
Alex Valder



# Exhibition design and architecture

# Exhibition design

# Elements and building blocks

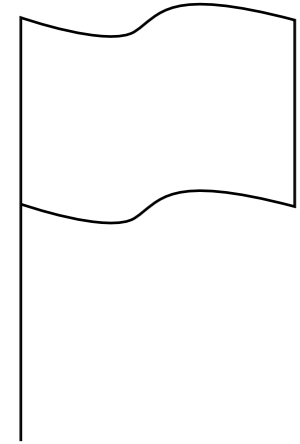

## Flag

Flags serve as both spatial landmarks and representations of identity within the exhibition; as well as points of orientation, they manifest claims to space in the form of an immediate visual statement.

Keywords:  
manifestation of presence / symbol of identity / position / statement / claim

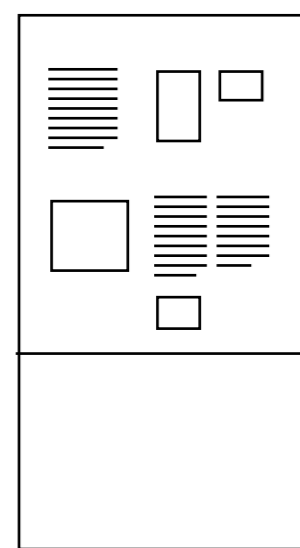

## Panel

As documents of ideas and a record of participation at the same time, panels inform and instigate further discussion, utilising a color-coded gradient system guides the viewer through the questions and topics.

Keywords:  
manifesto / declaration of opinion and ideas / witness / record / instigate / provoke / initiate / document

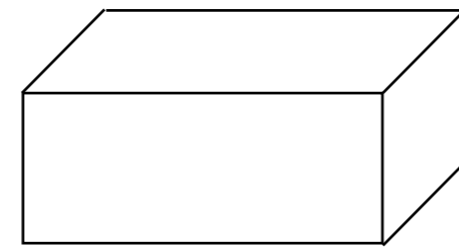

## Brick

The ultimate archetype of "space making", bricks delimited the fundamental spatial principles of interior/exterior, whilst acting as the fundamental components for a wide range of different constructions for display.

Keywords:  
foundation / interior-exterior / archetype of spatial component / node / base component

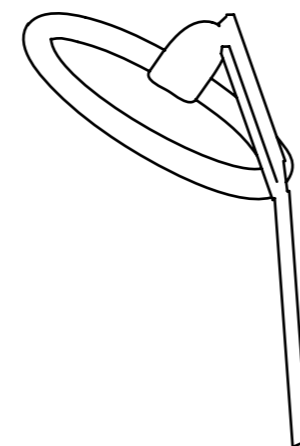

## Light

Referencing again the motif of the circle, lights are positioned on the modules to focus attention and encourage viewers to zoom in on particular topics and areas.

Keywords:  
lens / zoom in / focussing attention

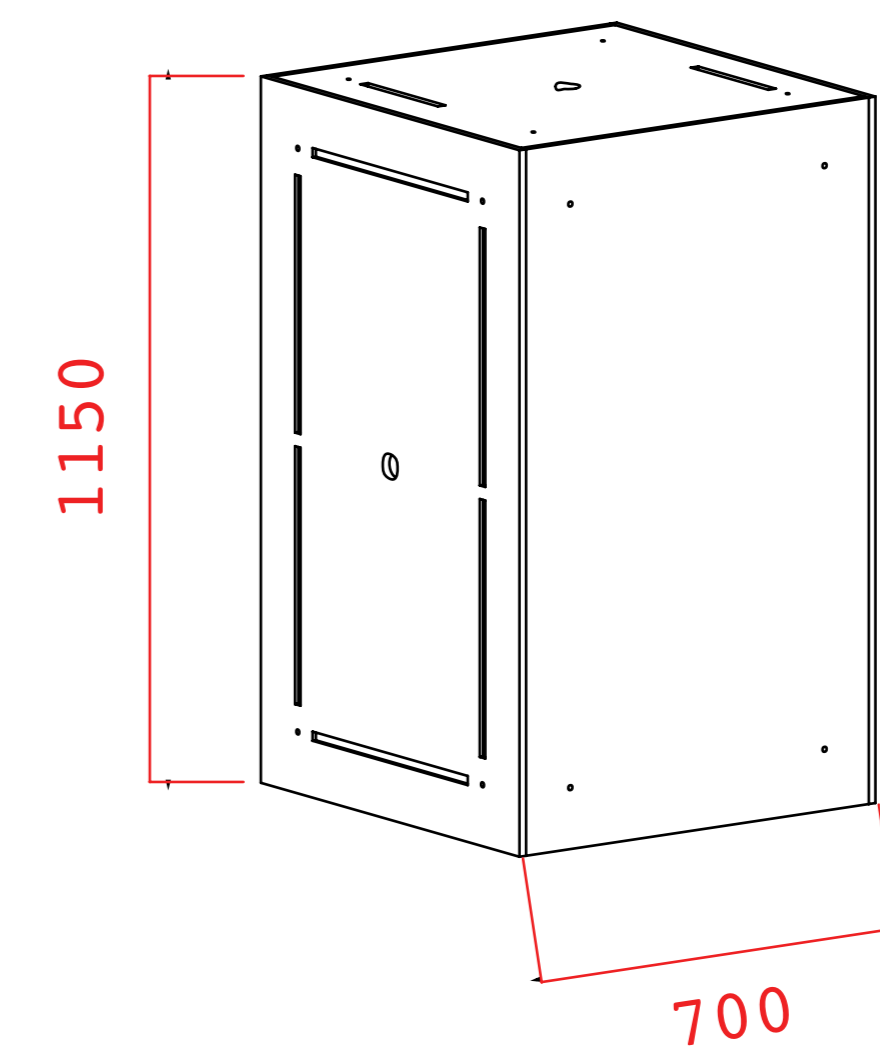
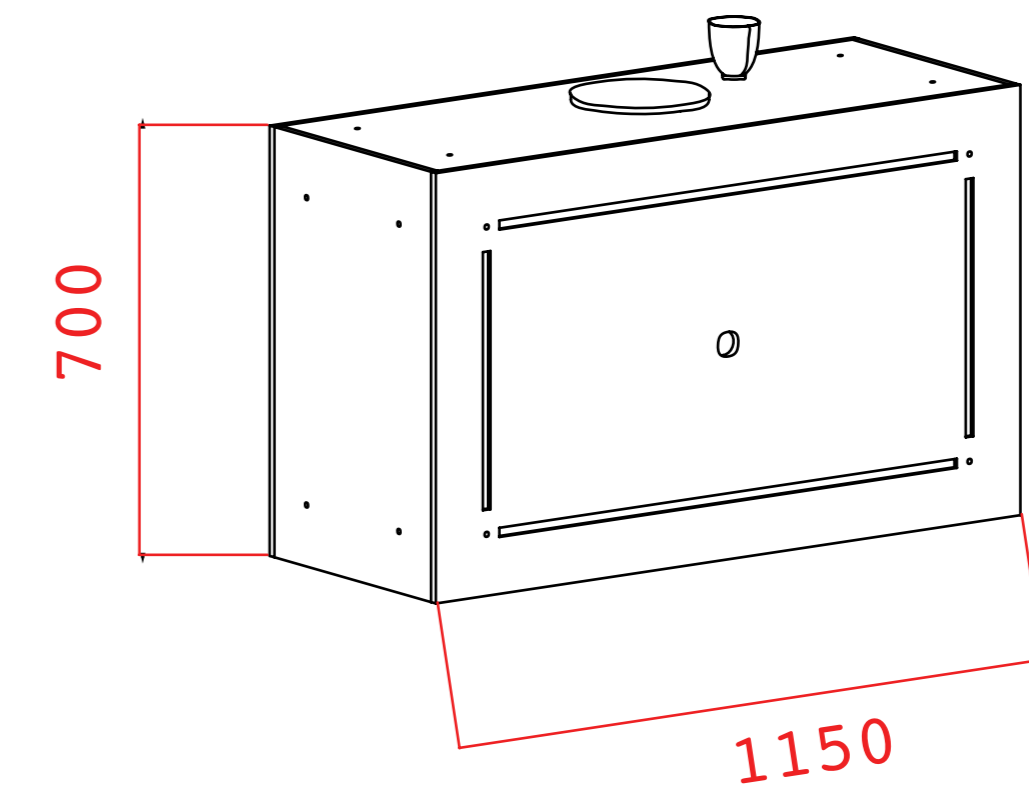
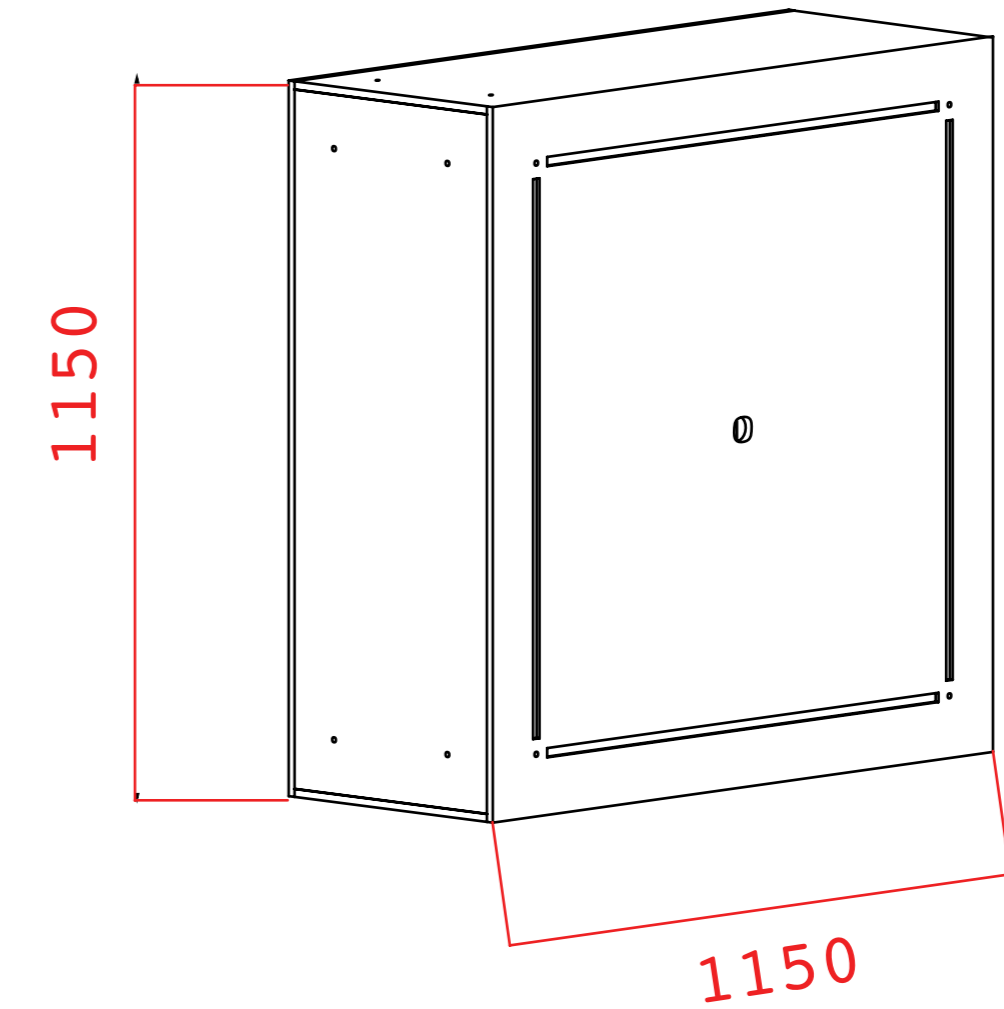

Exhibition design

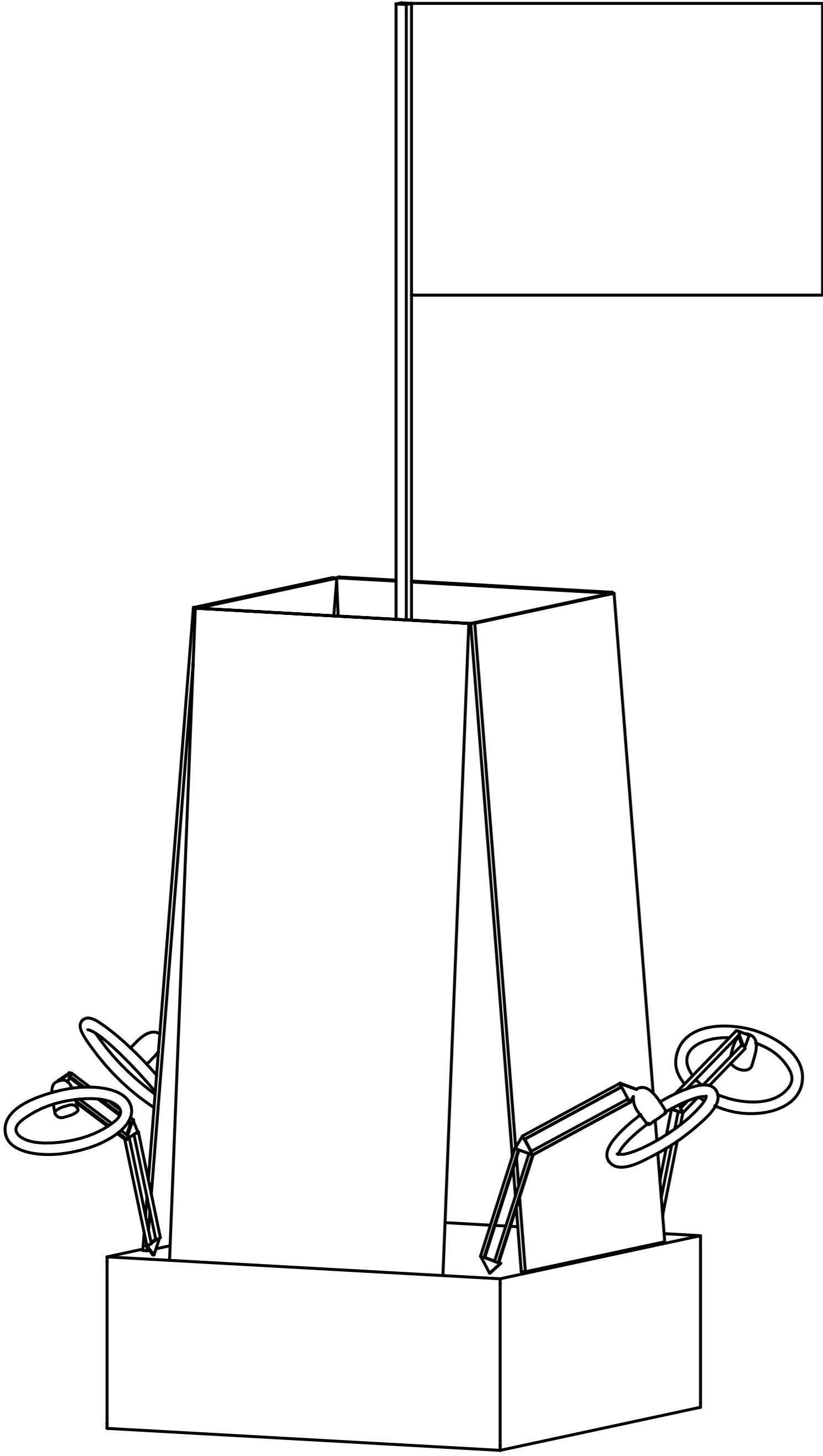

Thematic Islands

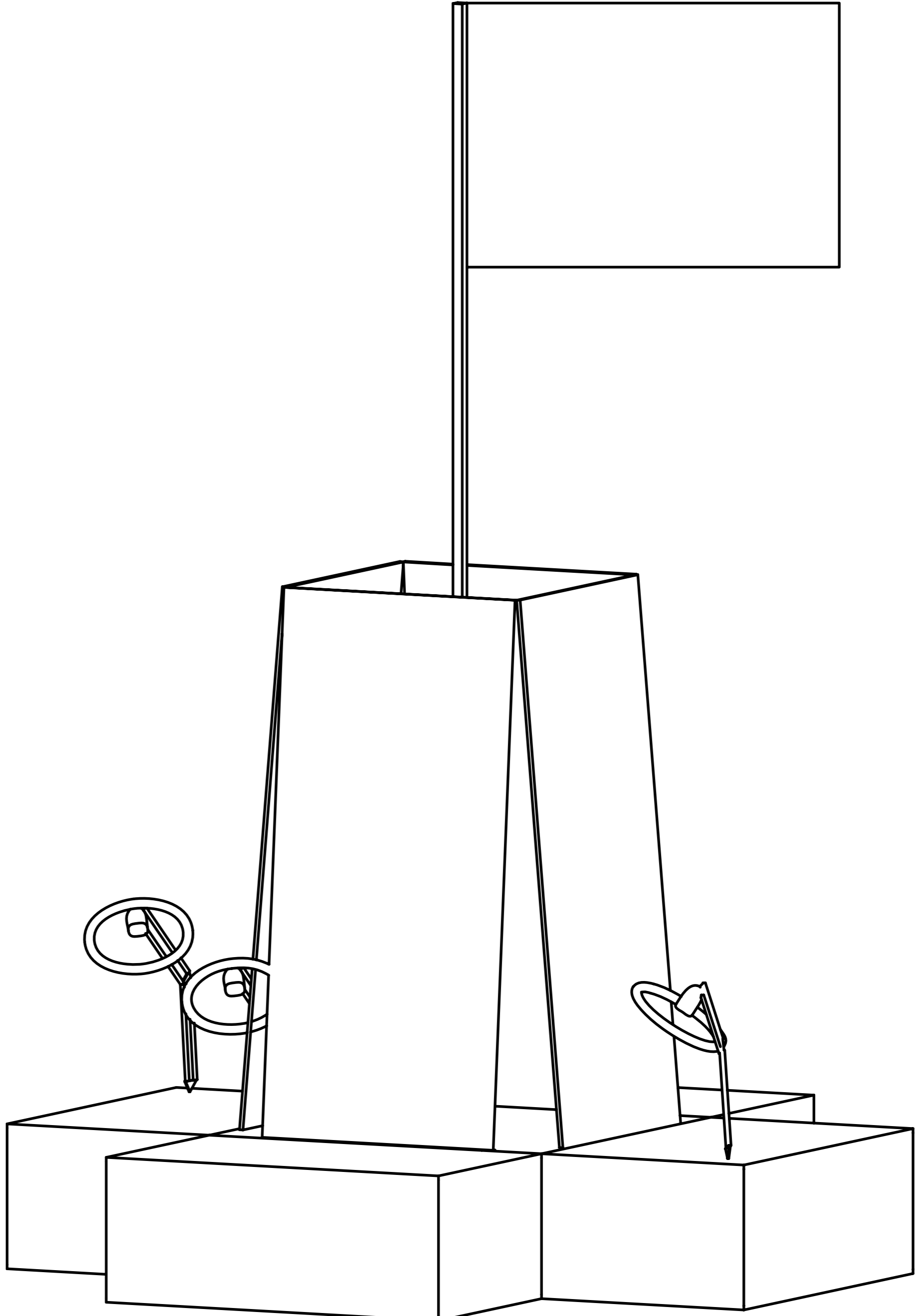

Exhibition design

Thematic Islands

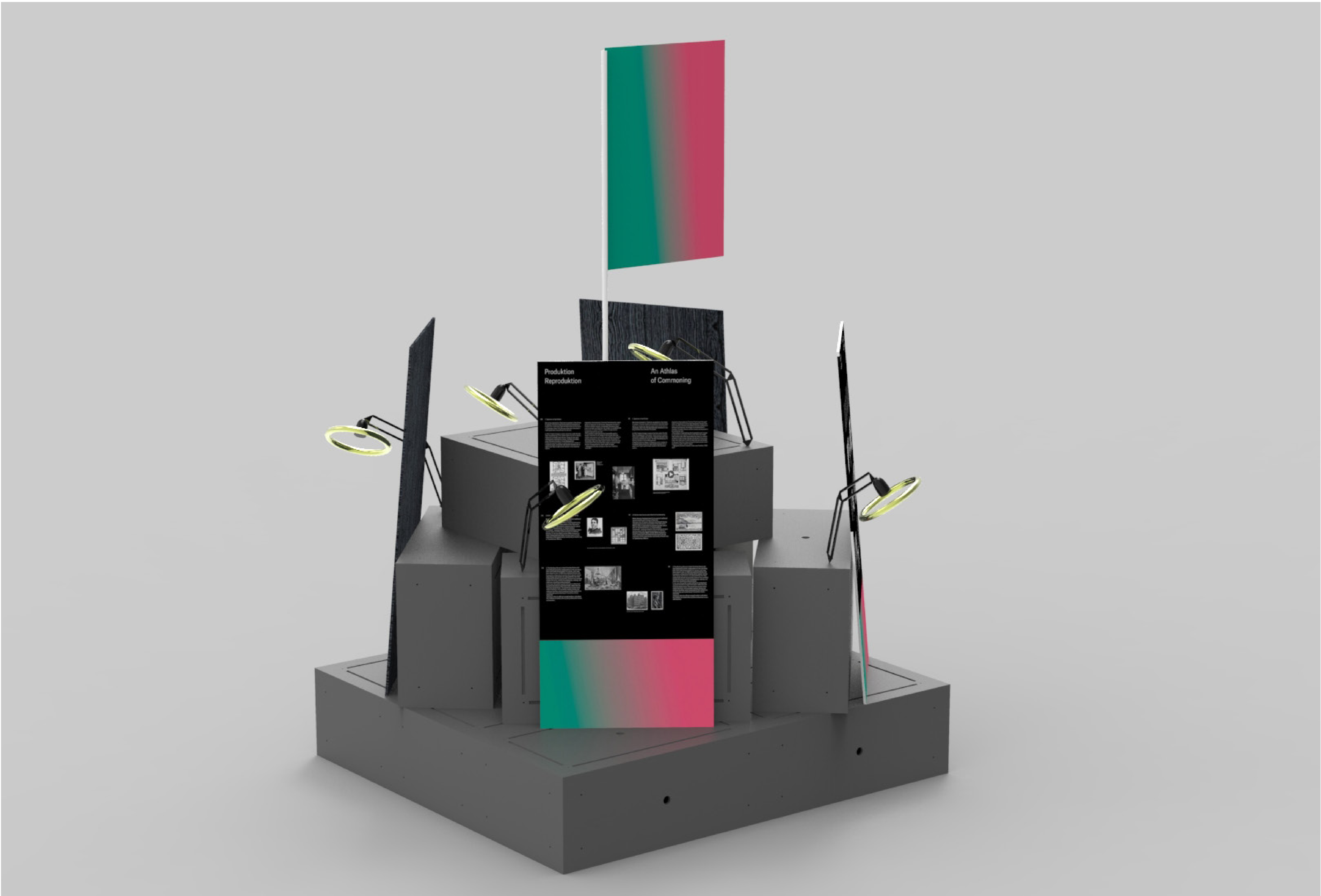

# Exhibition design

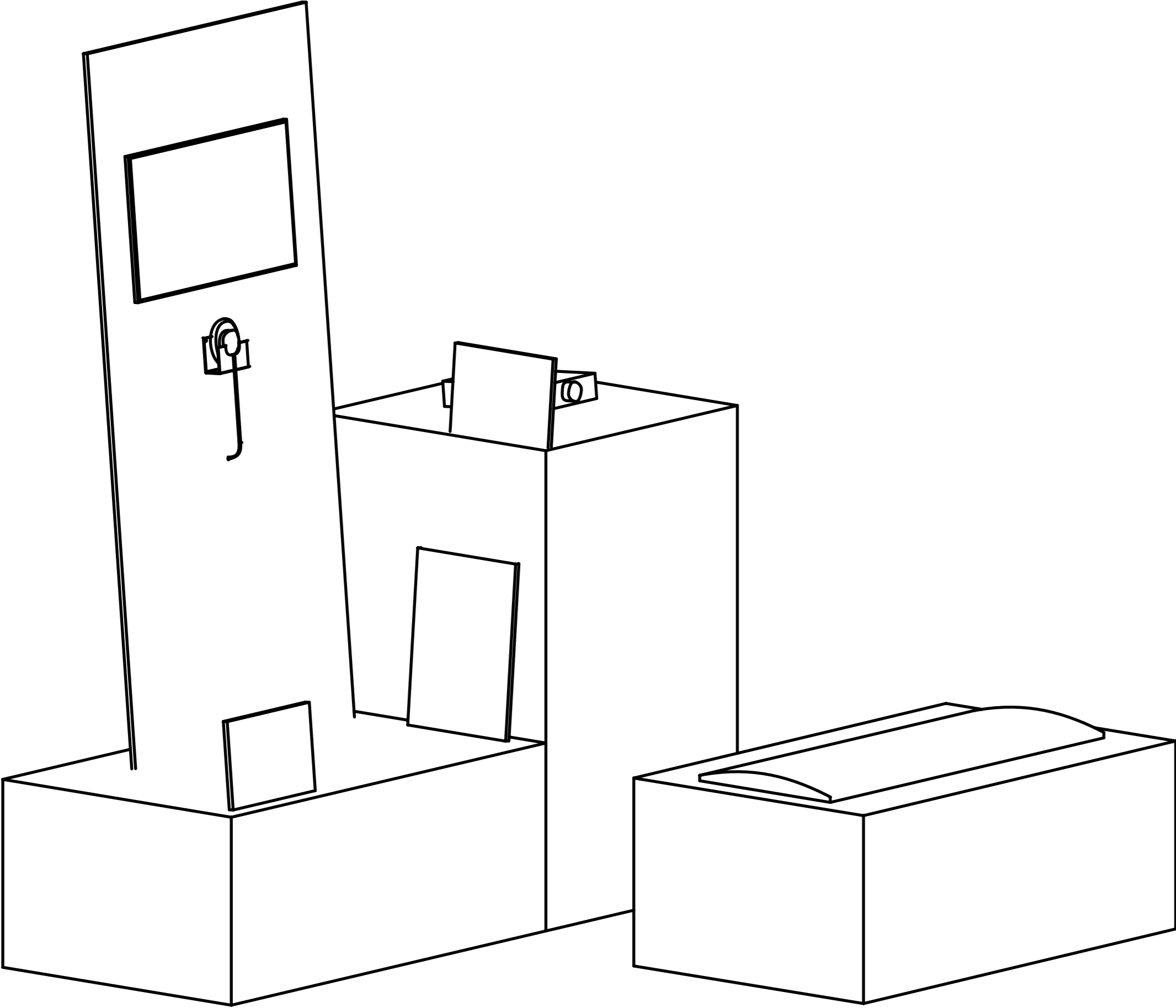

# Case studies

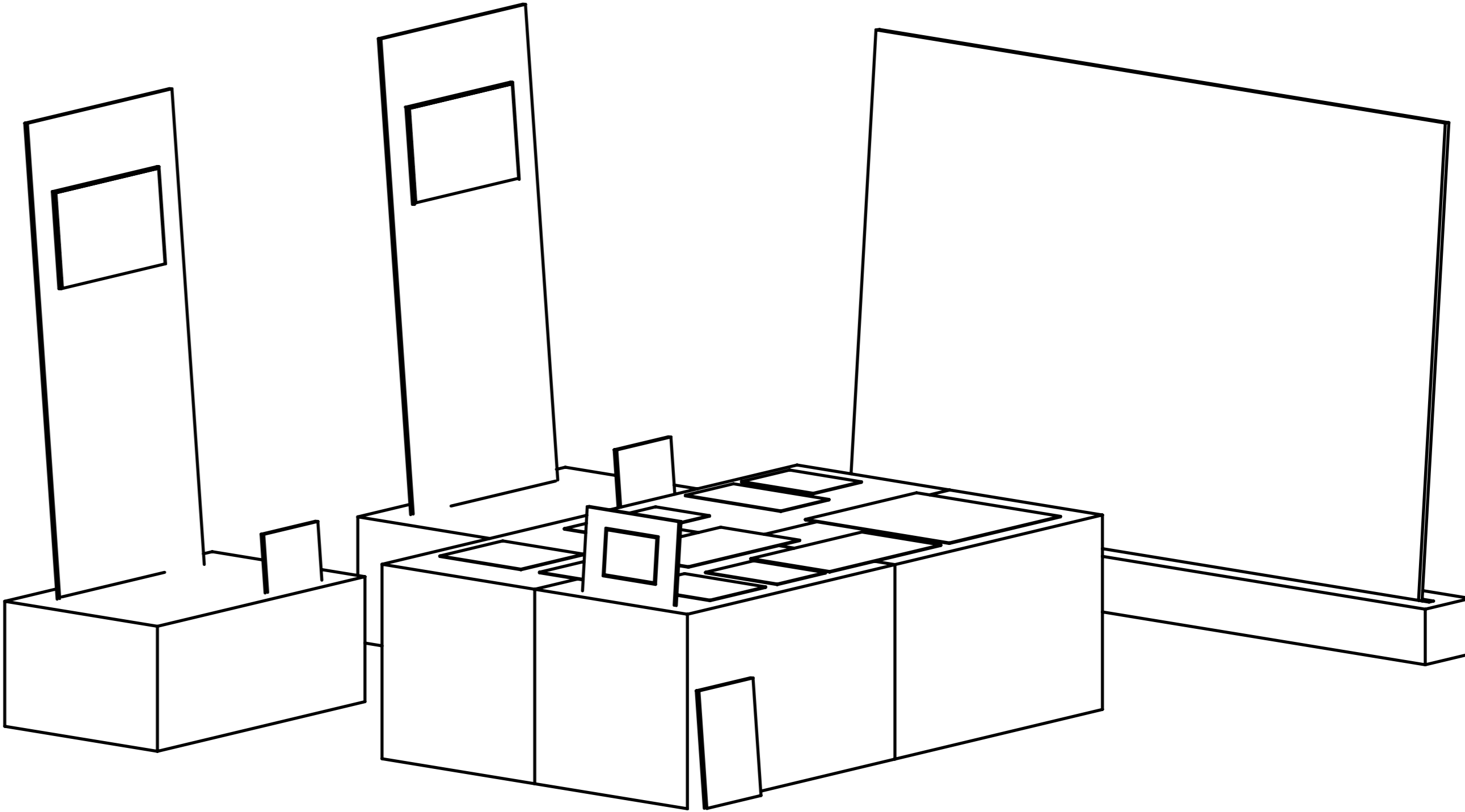

Exhibition design

Case studies





Exhibition design

Atlas



Exhibition design

Atlas

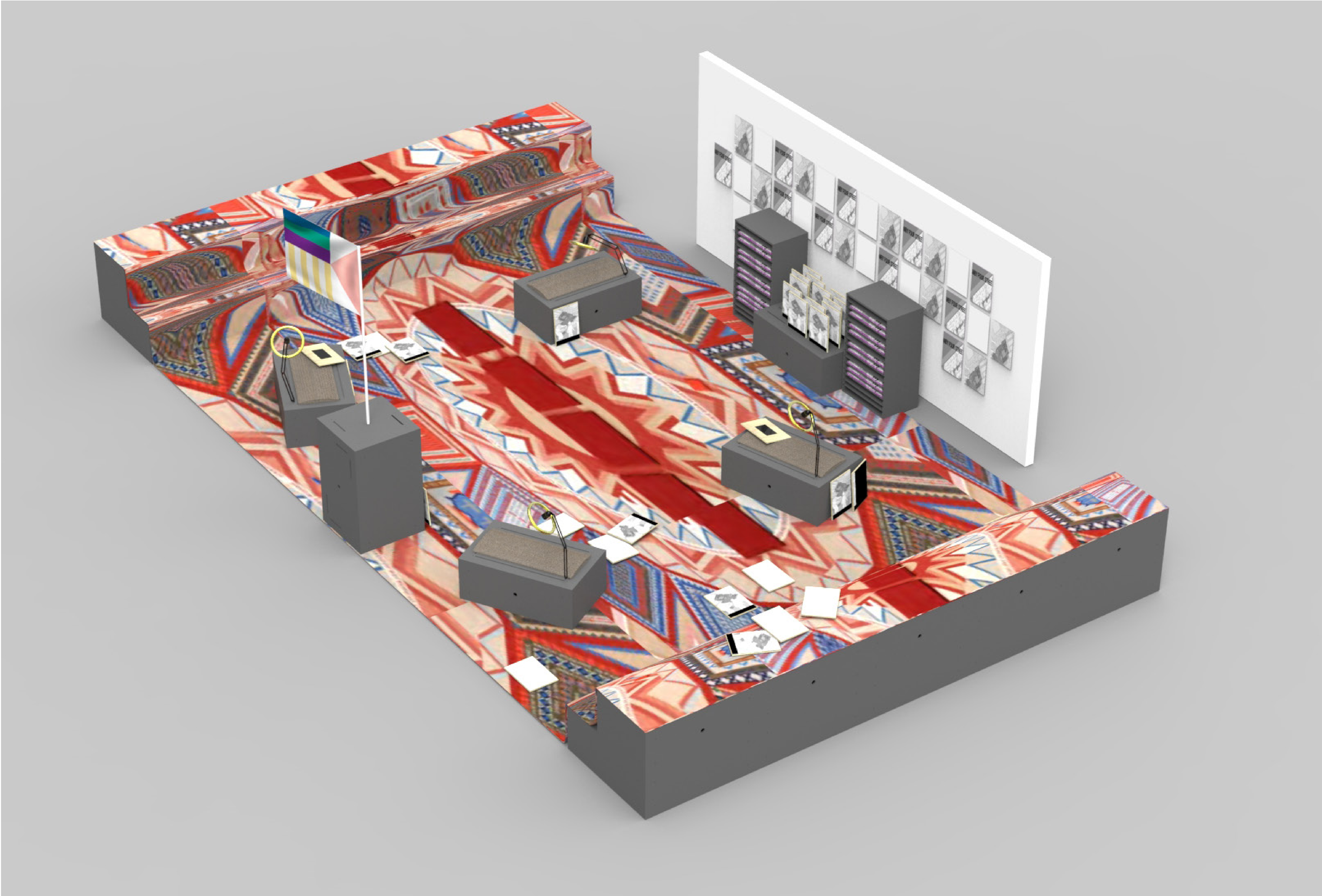

Exhibition design

Atlas

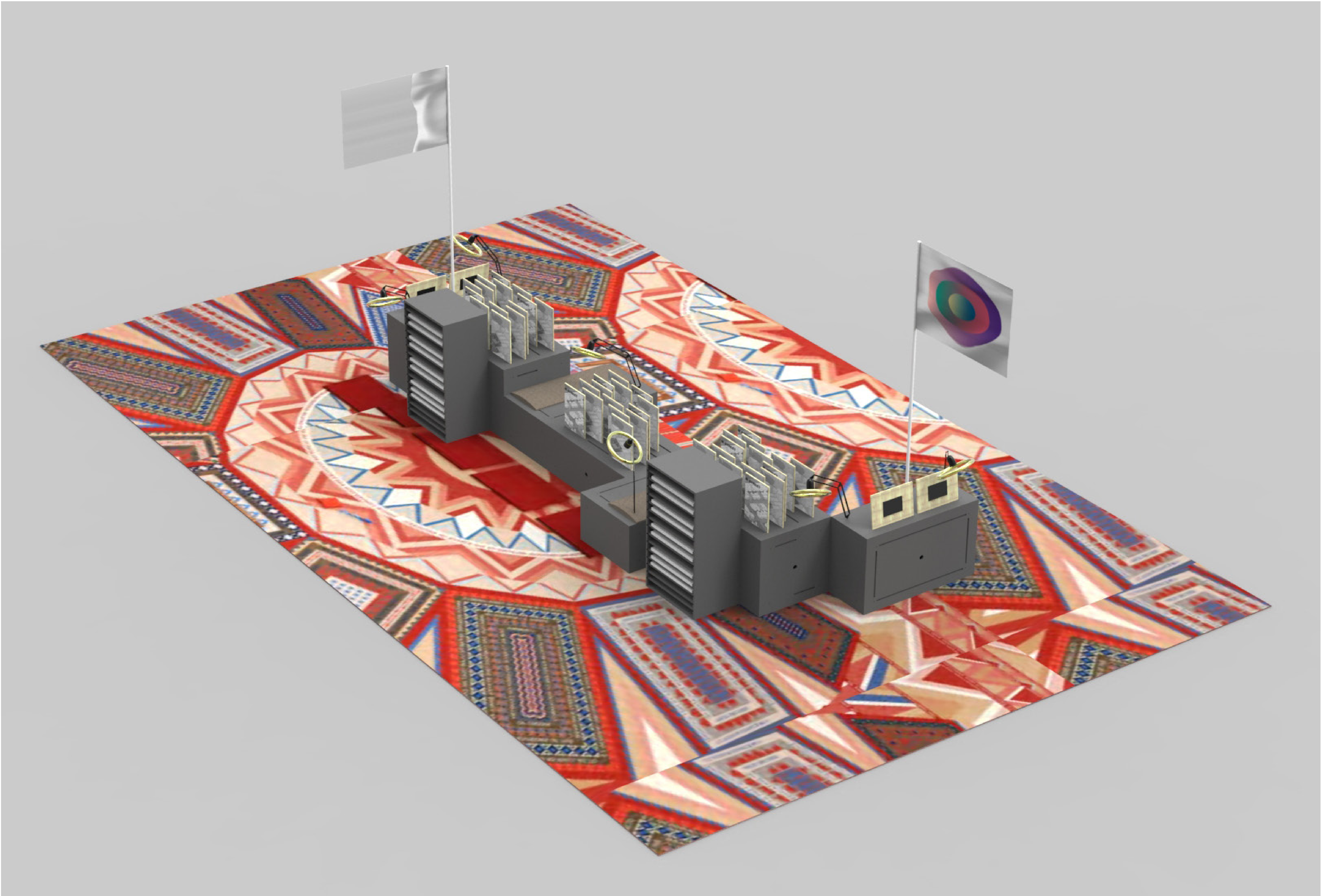

Exhibition design

Packing and shipping

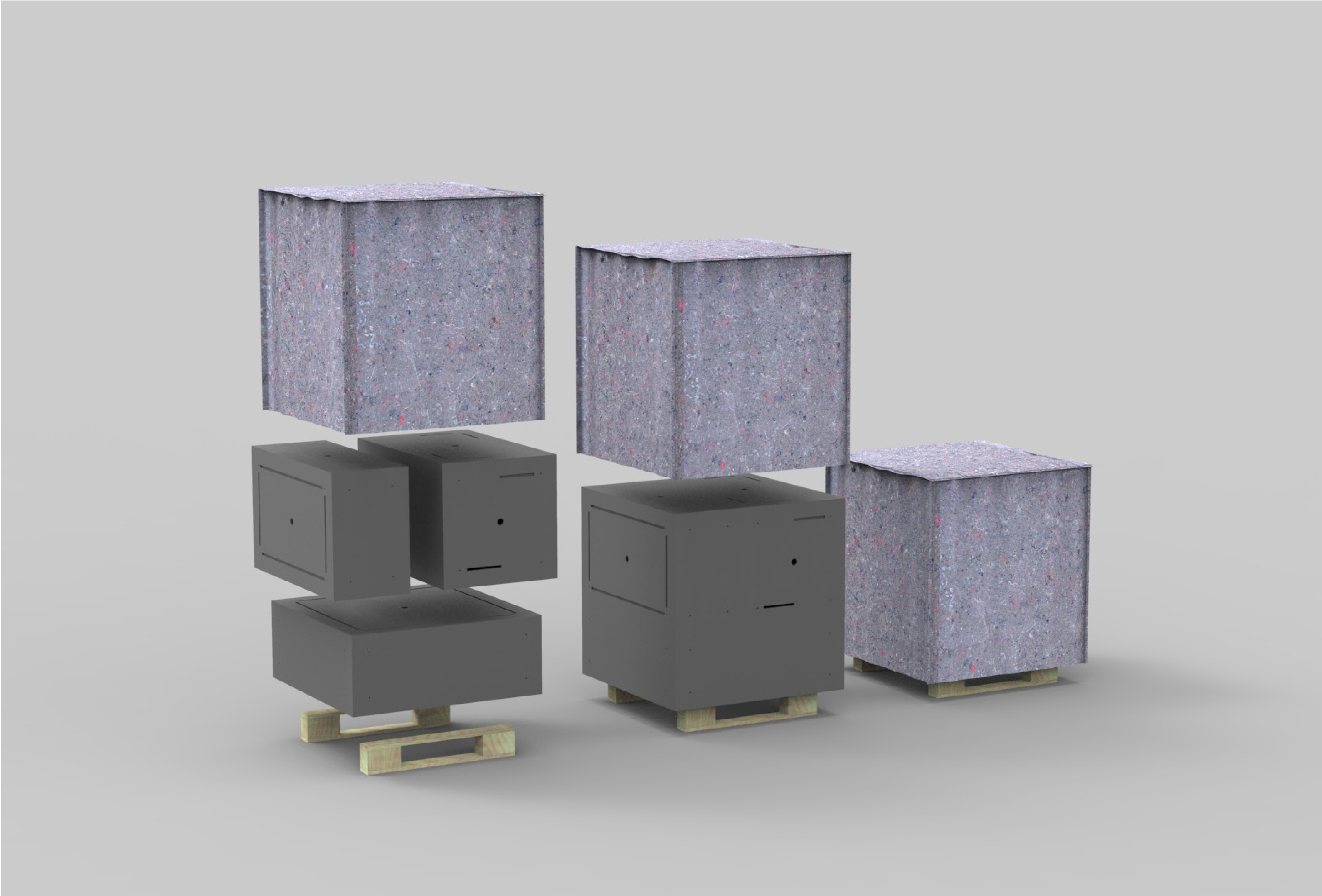

Exhibition design

Packing and shipping

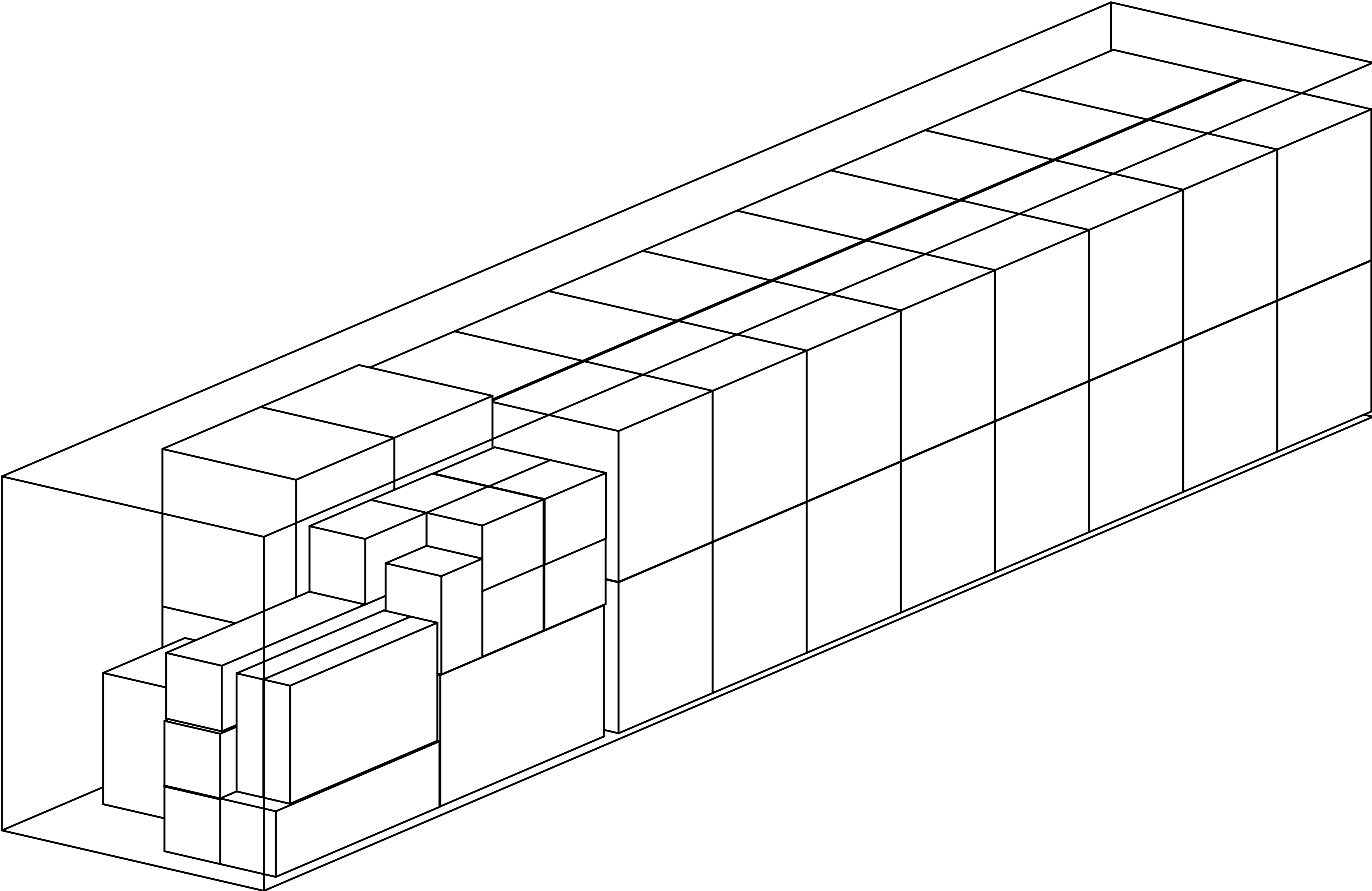

# Exhibition set-up

# Bandeja 2

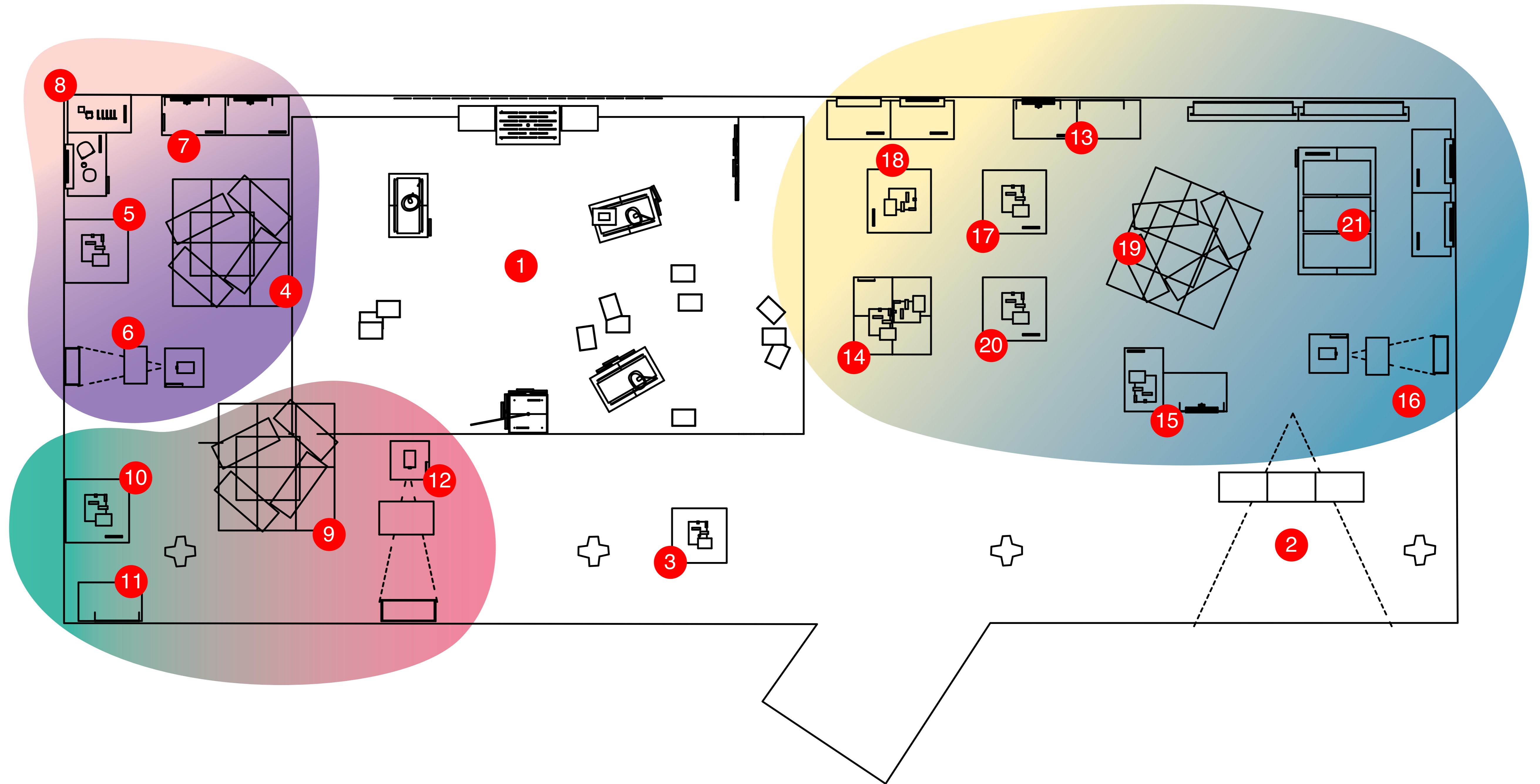

# Graphic design and visual language

Graphic design

Color coding

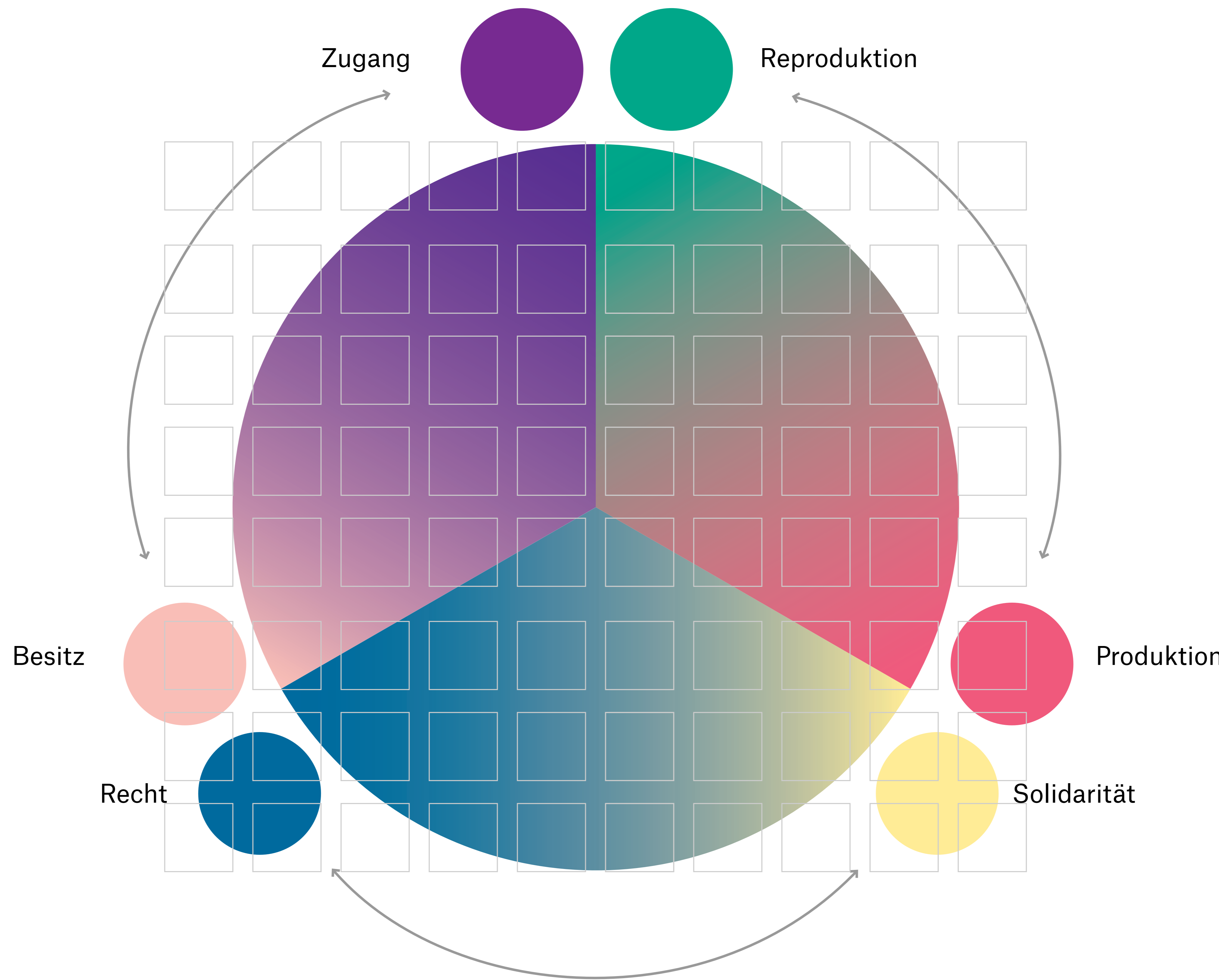



Graphic design

Color coding

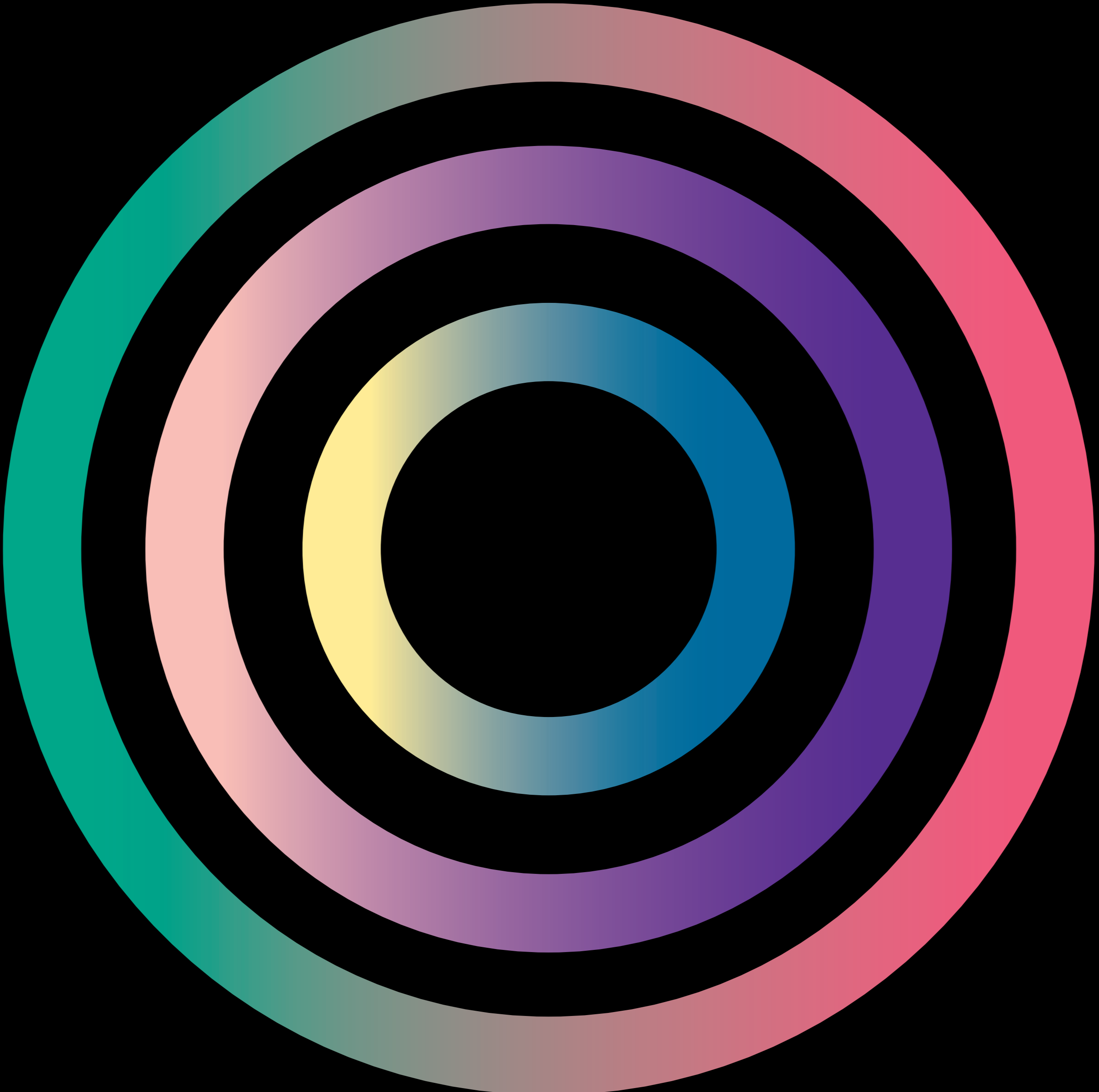

# Graphic design



Kitchenless homes and  
colective housekeeping

*M. S. Howland, USA/MEXICO*



Kitchenless homes and  
colective housekeeping

*M. S. Howland, USA/MEXICO*



Kitchenless homes and  
colective housekeeping

*M. S. Howland, USA/MEXICO*

## Kitchenless homes and colective housekeeping

*M. S. Howland, USA/MEXICO*

Ipientiorae volorit ratur mi, quatustrum, evelit voluptati aut odi quia  
nossunt ullores et exceratquas nulpā posapel molupta doluptatur, sim-  
porro volorer rumqui disque moluptatquo tem veligni enditat que vel mo  
dipsaperione nosto blanditiae nus doleseri tem ullautem. Nam eictur  
reperitatem sae consed eaque dolum lab iunto maxim que nos volecus-  
dae laborem erias de net veni que volupticia consentint voluptiistis ea  
corrumq uosanih illaccus, vel mo dolupta tionet atus, tem debit auten-  
dant esedio. Et ma vitibus mo dolenim quam nullab impelique perum  
eaquis ditio. Et ma corrovitem none volorepatatet faccum que nihit en-  
tur sedi audisci optur rehendae reperes dolestis aut ut que plit quam  
dolorepel molore sin nos modi accae rem esequi autate comnis exce-  
rum que voluptation essi alitae. Ucia porruntem eaquam incte volup-  
ta quoditem simpore pratqui aerrum sequaepe occullo reperorpor sed  
quiam se despistium corro quidebis natqui corerrupta des vendiosam  
que volorro cuptasipient moluptata aut il min por atusam haris dem-  
quiae ne consect oreictati aspīs ne nus inulluptat aligende soluptatori  
nonsedit fuga. Um arum quiaspid quae volorem et eturehenda sequis  
consecea quidem faciend ucitatio eos escit apid eum etur a sandem.  
Itatur? Qui is dolo con nat dolorem quatemq uiatio magniat ionsequatu-  
ri tem quidi comnimus earitas explignis aliscipit odi ut omnis mil et

# Tension fields

## Production Reproduktion

## An Atlas of Commoning

EN 1. Taylorism in the Kitchen  
Becoming interested in Taylorism as applied to the domestic sphere, Christine Frederick founded and directed a laboratory for conducting "typical" experiments at her home in Greenham, New York. She was especially interested in making kitchen more efficient for women.

In 1912, Frederick began a series of articles under the title "New Housekeeping in the Ladies' Home Journal" to explain Taylorism to middle-class women. These articles were subsequently published as a book, *The New Housekeeping: Efficiency Studies in Home Management*. Frederick's second chapter, on applying motion studies to household tasks, shows the clear parallel between her research and Taylor's well-known studies in the industrial sphere.

Inspired on the studies by Christine Frederick and her application of Taylorism to the kitchen, Margarete Schütte-Lihotzky's Frankfurt kitchen (initially) became a milestone in domestic architecture. Her design is considered the forerunner of modern fitted-a kitchen concept and designed to be built at low cost.

It is the problem of rationalizing the housewife's work is equally important to all classes of the society. Both the middle-class women, who often work without any help (or, without servants) in their homes, and also the women of the working class, who often have to work in other jobs, are overworked to the point that their stress is bound to have serious consequences for public health at large."  
— Margarete Schütte-Lihotzky in *Das neue Frankfurt*, 1926/927

DE 1. Taylorism in the Kitchen  
Becoming interested in Taylorism as applied to the domestic sphere, Christine Frederick founded and directed a laboratory for conducting "typical" experiments at her home in Greenham, New York. She was especially interested in making kitchen more efficient for women.

In 1912, Frederick began a series of articles under the title "New Housekeeping in the Ladies' Home Journal" to explain Taylorism to middle-class women. These articles were subsequently published as a book, *The New Housekeeping: Efficiency Studies in Home Management*. Frederick's second chapter, on applying motion studies to household tasks, shows the clear parallel between her research and Taylor's well-known studies in the industrial sphere.

Inspired on the studies by Christine Frederick and her application of Taylorism to the kitchen, Margarete Schütte-Lihotzky's Frankfurt kitchen (initially) became a milestone in domestic architecture. Her design is considered the forerunner of modern fitted-a kitchen concept and designed to be built at low cost.

It is the problem of rationalizing the housewife's work is equally important to all classes of the society. Both the middle-class women, who often work without any help (or, without servants) in their homes, and also the women of the working class, who often have to work in other jobs, are overworked to the point that their stress is bound to have serious consequences for public health at large."  
— Margarete Schütte-Lihotzky in *Das neue Frankfurt*, 1926/927

EN 2. Kitchen-less homes and collective housekeeping  
Marie Stevens Howland stood firmly against traditional social morality and in favor of free love. She was a fan of Fourier's theories lived herself among several experimental communities in the USA and in Mexico. She is responsible for popularizing the radical idea of "housekeeping" or "house without housework", arguing instead for the socializing of reproductive labor and the implementation of collective kitchens. In the late 1840s and the 1850s, Howland actively collaborated with Albert Kinsey Owen's for the realization of the experimental community of Pacific City in Topsham, Maine.

DE 2. Kitchen-less homes and collective housekeeping  
Marie Stevens Howland stood firmly against traditional social morality and in favor of free love. She was a fan of Fourier's theories lived herself among several experimental communities in the USA and in Mexico. She is responsible for popularizing the radical idea of "housekeeping" or "house without housework", arguing instead for the socializing of reproductive labor and the implementation of collective kitchens. In the late 1840s and the 1850s, Howland actively collaborated with Albert Kinsey Owen's for the realization of the experimental community of Pacific City in Topsham, Maine.

EN 3. The Working Women's Hotel Charlotte Perkins Gilman believed economic independence is the only thing that could really bring freedom for women, and make them secure in men. In 1849, she published *Women and Economics*, a theoretical treatise which argued, among other things, that women are subsquidged by men, that motherhood should not distract a woman from working outside the home, and that housekeeping, cooking, and child care, should be professionalized.

In her view, the perfect spatial setting for motherhood would be the feminist apartment hotel, rather than the Victorian family house. This would have private suites without kitchens, and complete cooking, dining, and childcare facilities, which would permit the residents to combine jobs and motherhood. It would be a home where the cleaning is done by efficient waged workers, and where the children are looked after by paid professional nurses and teachers.

DE 3. The Working Women's Hotel Charlotte Perkins Gilman believed economic independence is the only thing that could really bring freedom for women, and make them secure in men. In 1849, she published *Women and Economics*, a theoretical treatise which argued, among other things, that women are subsquidged by men, that motherhood should not distract a woman from working outside the home, and that housekeeping, cooking, and child care, should be professionalized.

In her view, the perfect spatial setting for motherhood would be the feminist apartment hotel, rather than the Victorian family house. This would have private suites without kitchens, and complete cooking, dining, and childcare facilities, which would permit the residents to combine jobs and motherhood. It would be a home where the cleaning is done by efficient waged workers, and where the children are looked after by paid professional nurses and teachers.



Graphic design

Output

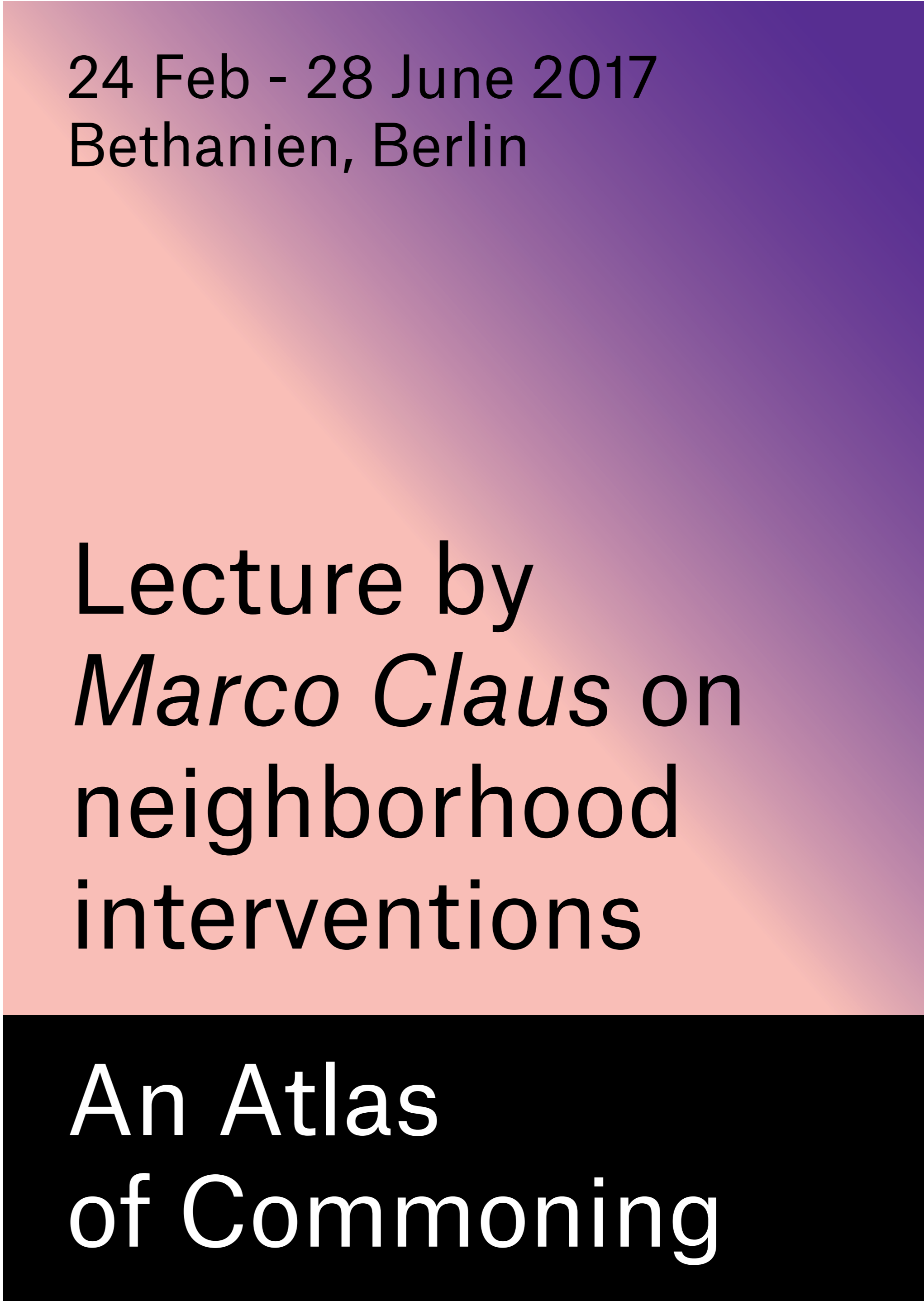

## Graphic design

24 Feb - 28 June 2017  
Bethanien, Berlin

Lecture by  
*Marco Claus* on  
neighborhood  
interventions

An Atlas of Commoning

## Output

Lecture by *Marco Claus* on  
neighborhood interventions

Wednesday 24th of June  
20:00 - 21:00, Bethanien

Um exceptae expliquis enet harcipsus volo  
ernaturepro eost exceaque ene rem recture  
autessimet quae volest a vel eatius, que vol-  
or aliatibus verem et laboressunt as nossedi  
cusanti exceaque omnimenis es volorum  
prore, et utem

Um exceptae expliquis enet harcipsus volo  
ernaturepro eost exceaque ene rem recture  
autessimet quae volest a vel eatius, que vol-  
or aliatibus verem et laboressunt as nossedi  
omnimenis es volorum prore, et utem

Graphic design

Output



24 Feb - 28 June 2017  
Bethanien, Berlin

*Manuel Herz,  
Marisa Gonzales,  
Samson Young,  
Morehshin Allahyuari,  
Julian Charrière*

**An Atlas  
of Commoning**

24 Feb - 28 June 2017  
Bethanien, Berlin

*Manuel Herz,  
Marisa Gonzales,  
Samson Young,  
Morehshin Allahyuari,  
Julian Charrière*

**An Atlas  
of Commoning**

24 Feb - 28 June 2017  
Bethanien, Berlin

Lecture by  
*Marco Claus* on  
neighborhood  
interventions

**An Atlas  
of Commoning**

Graphic design

Output



Graphic design

Output



Graphic design



Output





Graphic design

Output

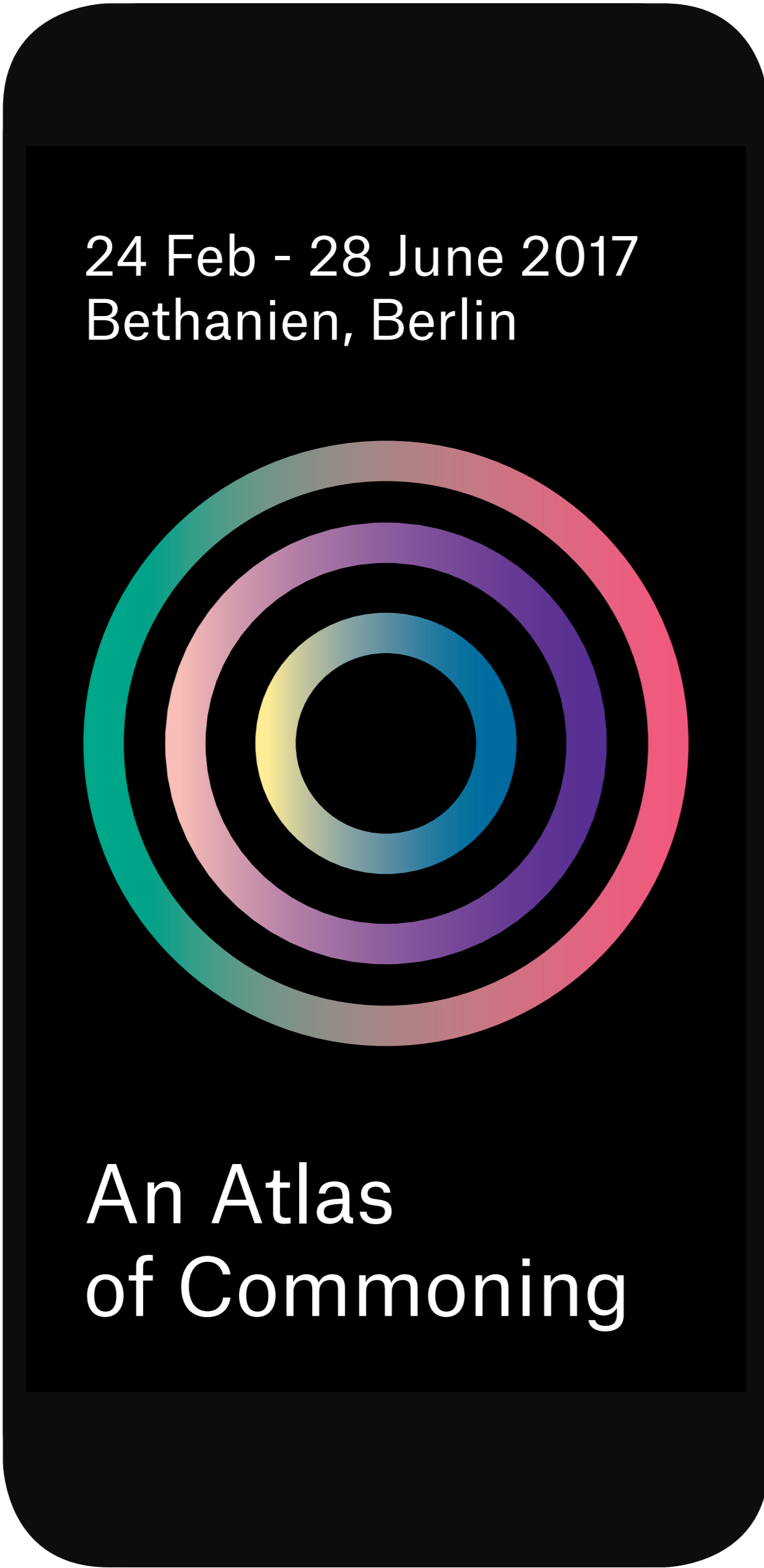

24 Feb - 28 June 2017  
Bethanien, Berlin

An Atlas  
of Commoning

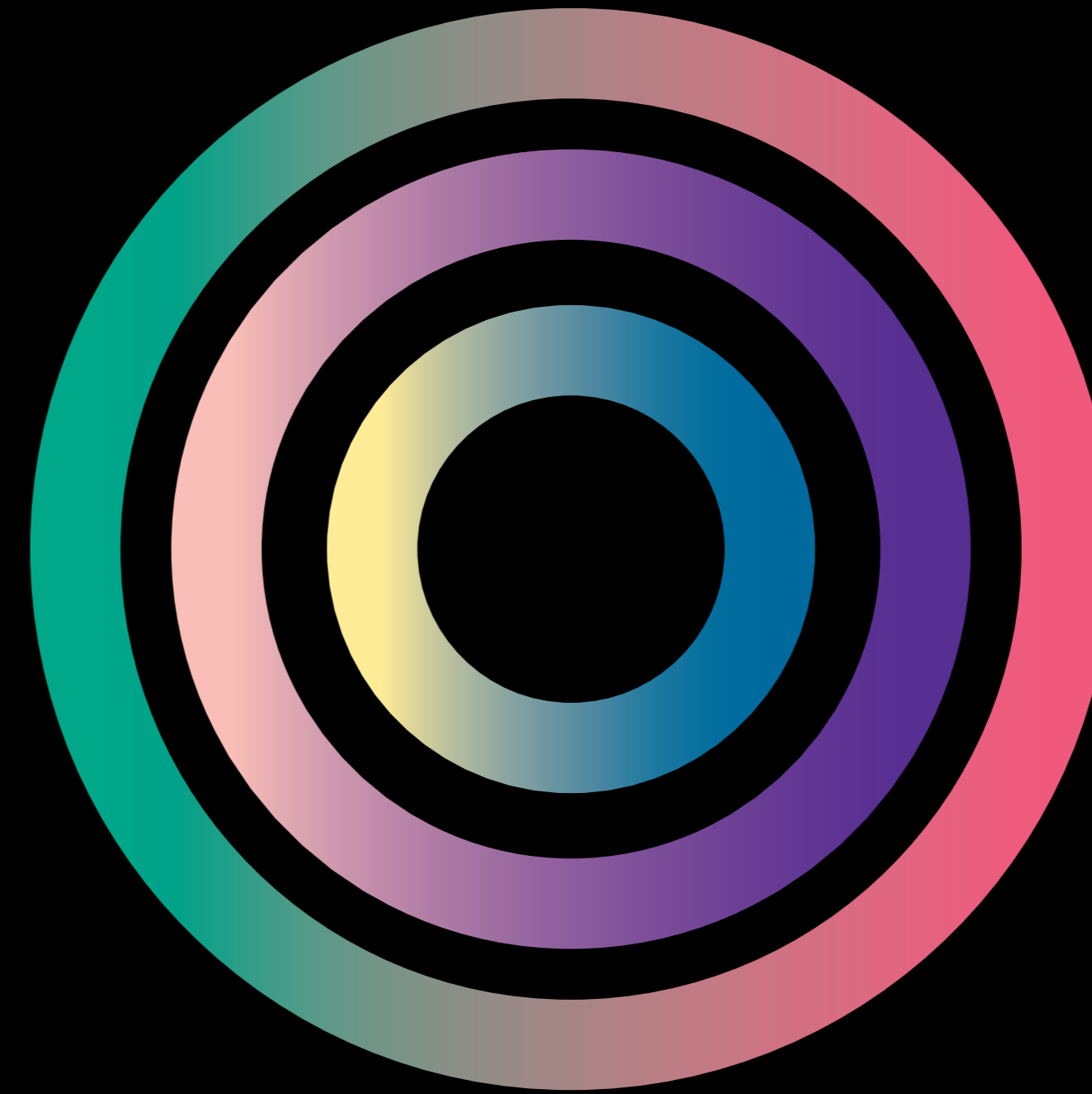

# An Atlas of Commoning

[Atlas](#) [Library](#) [Participants](#) [Themes](#) [About](#)



Der Begriff der Commons hat Konjunktur. Zahlreiche Projekte und Theorien haben sich in den letzten Jahren um ihn und verwandte Begriffe wie Gemeingut und Allmende, Genossenschaft und Kooperative oder neuere Ansätze wie Open Source und Shar-



Graphic design

Output

